

# ***USER'S MANUAL***

---

## ***TEHX-C*** ***SINGLE HEAD***

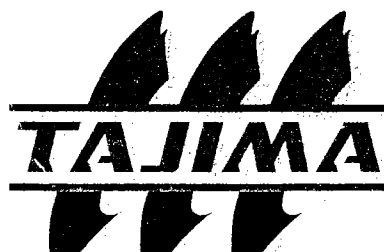

This User's Manual contains information useful for operating TAJIMA Automatic Embroidery Machine, Model TEHX-C. Persons who touch a machine for the first time, as well as those who are experienced in the machine operation, will find this manual helpful for understanding and performing the machine operation procedures. Please read through this manual and understand the contents before operating the machine.

The contents of this manual are largely divided into the following sections.

- [IMPORTANT WARNING ITEMS FOR SAFE OPERATION]**
- [MACHINE CONSTRUCTION]**
- [OPERATION BASICS]**
- [DATA OPERATION]**
- [MACHINE OPERATION]**
- [MACHINE SETTING]**
- [SETTING ON EMBROIDERY]**
- [SETTING ON OPTIONS]**
- [OUTLINE OF FUNCTIONS]**
- [TROUBLESHOOTING AND MAINTENANCE]**
- [APPENDIX]**

Concerning optional devices, please refer to the instruction manual of the optional device you have purchased.

This manual may contain discrepancies in detailed information when compared with the actual machine due to continued research and improvements. If any question about the machine contents of this manual arises, please consult your TAJIMA distributor.

Please keep this manual near the machine for immediate reference. When this manual is not used, keep it carefully.

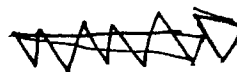

Operation of this machine requires correct operation and appropriate maintenance to ensure safety. Please read the IMPORTANT SAFETY INSTRUCTIONS in this manual carefully and do not attempt operation or maintenance of the machine before you thoroughly understand the items written under IMPORTANT SAFETY INSTRUCTIONS.

Items that require your special attention on operation and maintenance of the machine are specified below with the warning symbol and signal word. These items must be strictly observed to ensure safety during operation and maintenance.

Signal word definition is given below.

## DANGER

Indicates that there is a lot of danger of death or serious injuries [\* 1] if the instruction is not observed.

## WARNING

Indicates that there is a likelihood of death or serious injuries [\* 1] if the instruction is not observed.

## CAUTION

Indicates a potentially hazardous situation which, if not avoided, may result in minor or moderate injury [\* 2] or property damage.

- \*1: A condition caused by electric shock, injury, fracture of a bone, etc., that leads to sequelae, or an injury that necessitates hospitalization or visits to a hospital over a long period.
- \*2: An injury that does not necessitate hospitalization or visit to a hospital over a long period.

 :Prohibited items

 :Items that must be followed carefully to ensure safe operation.

The information which gives details or supplements the explanation appears under the title **NOTE**.

<b>IMPORTANT WARNING ITEMS FOR SAFE OPERATION .....</b>		<b>1</b>
1.	MACHINE INSTALLATION ENVIRONMENT .....	i
2.	CAUTIONS ON MACHINE OPERATION .....	ii
3.	WARNING LABELS AND SPEC. PLATE .....	v
3-1.	Positions of Warning Labels and Spec. Plate .....	v
3-2.	Contents of Warning Labels .....	vi

**CHAPTER 1 MACHINE CONSTRUCTION.....1-1**

1.	FEATURES AND FUNCTIONS .....	1-1
2.	ELECTRICAL SPECIFICATIONS .....	1-3
2-1.	Switching Power Supply Specifications .....	1-3
3.	NAMES OF PARTS .....	1-4
4.	OPERATION PANEL BOX.....	1-5
4-1.	Explanation and Function of Each Part.....	1-5
4-2.	Functions of Setting Keys .....	1-7
5.	TENSION BASE SWITCH AND THREAD BREAKAGE INDICATOR LAMP ..	1-11
6.	POWER SUPPLY / DRIVER UNIT .....	1-12
7.	DIP SWITCH SETTING .....	1-13

**CHAPTER 2 OPERATION BASICS .....2-1**

1.	STARTING AND STOPPING THE MACHINE .....	2-1
1-1.	Power Switch .....	2-1
1-2.	Emergency Stop Switch .....	2-1
1-3.	Operation by Start Switch/Stop Switch .....	2-2
2.	OPERATION BASICS .....	2-3
2-1.	Precautions on Handling Floppy Disks and Floppy Disk Drive (FDD) .....	2-3
3.	SOFTWARE INSTALLATION .....	2-5
3-1.	Procedure.....	2-5
4.	DISPLAY SCREEN .....	2-9
4-1.	Display after Turning the Power ON .....	2-9
4-2.	Normal Display.....	2-9
4-3.	Display during Operation.....	2-9
5.	INSPECTIONS BEFORE STARTING OPERATION.....	2-10
6.	BASIC OPERATION FLOW.....	2-11
7.	GENERAL DESCRIPTION OF SETTING AND OPERATING ITEMS .....	2-12

**CHAPTER 3 DATA OPERATION.....3-1**

1.	DATA INPUT .....	3-1
1-1.	Data Input (Memory) .....	3-1
1-2.	Data Input (Floppy Disk) .....	3-3
1-3.	Data Input (Serial) .....	3-5
2.	MEMORY DELETE .....	3-7
2-1.	Memory Delete.....	3-7
3.	DATA EDIT .....	3-11
3-1.	Data Edit (Modify) .....	3-11
3-2.	Data Edit (Insert).....	3-17
3-3.	Data Edit (Delete).....	3-23
3-4.	Data Edit (Cleanup).....	3-28
4.	FLOPPY DISK OPERATION .....	3-30
4-1.	Floppy Disk Processing (Save).....	3-30
4-2.	Floppy Disk Processing (Delete).....	3-34
4-3.	Floppy Disk Processing (Format).....	3-36

**CHAPTER 4 MACHINE OPERATION .....4-1**

1. MANUAL OPERATION .....	4-1
1-1. Manual Color Change .....	4-1
1-2. Manual Thread Trimming .....	4-3
1-3. Manual Origin Return .....	4-4
1-4. Manual Offset .....	4-5
1-5. Trace .....	4-6
1-6. Manual Frame Traveling .....	4-7
1-7. Frame Back / Forward .....	4-10
1-8. Frame Origin Memory .....	4-13
1-9. Power Resume .....	4-15
2. CONFIRMATION OPERATION .....	4-18
2-1. Total Stitch Counter / Design Timer .....	4-18
2-2. Confirmation Mode .....	4-20

**CHAPTER 5 MACHINE SETTING .....5-1**

1. MAIN SHAFT RPM .....	5-1
1-1. Maximum RPM .....	5-1
1-2. Low Speed RPM .....	5-3
1-3. Maximum RPM Limit .....	5-5
2. NUMBER OF START INCHING TIMES .....	5-7
2-1. Number of Start Inching Times .....	5-7
3. FRAME DRIVE .....	5-9
3-1. Frame Drive Start Timing .....	5-9
3-2. Frame Travel Speed .....	5-11
3-3. Frame Back/Forward .....	5-12
4. ATH .....	5-16
4-1. ATH Drive Start Timing .....	5-16

**CHAPTER 6 SETTING ON EMBROIDERY .....6-1**

1. THREAD BREAKAGE DETECTION AND THREAD TRIMMING .....	6-1
1-1. Upper Thread Breakage Detection .....	6-1
1-2. Under Thread Breakage Detection (Detection Method) .....	6-5
1-3. Under Thread Breakage Detection (Movement Ratio) .....	6-9
1-4. Automatic Thread Trimming .....	6-13
2. EMBROIDERY METHOD .....	6-17
2-1. Automatic Color Change/Automatic Start .....	6-17
2-2. Needle Bar Selection .....	6-19
2-3. Repeat .....	6-25
2-4. Automatic Offset .....	6-30
2-5. Auto Free-setting Offset .....	6-32
2-6. Automatic Start after Automatic Data Set .....	6-35
2-7. Automatic Origin Return .....	6-36
2-8. Preset Halt .....	6-37
2-9. Pseudo-fixed Position Stop .....	6-40
3. DATA PROCESSING .....	6-42
3-1. Data Conversion .....	6-42
3-2. Jump Conversion .....	6-45
3-3. Automatic Jump .....	6-47
3-4. Satin Stitch .....	6-48
3-5. Backlash .....	6-49

<b>CHAPTER 7 SETTING FOR OPTIONS .....</b>	<b>7-1</b>
1. OPTIONS .....	7-1
1-1. Boring Device.....	7-1
1-2. Cording Device.....	7-3
1-3. Network .....	7-4
1-4. Auto Ribbon Feeding Device .....	7-6
1-5. Under Thread Trimming Selection .....	7-8
 <b>CHAPTER 8 OUTLINE OF FUNCTIONS.....</b>	 <b>8-1</b>
1. DATA CONVERSION .....	8-1
2. REPEAT.....	8-3
2-1. X/Y Repeat Priority.....	8-3
2-2. X/Y Repeating Direction.....	8-3
2-3. Mirror Image Repeat .....	8-4
3. OFFSET .....	8-6
4. SATIN STITCH.....	8-8
5. BACKLASH.....	8-9
5-1. Method to Judge Reversion of Coordinate Polarity.....	8-9
6. TRACE .....	8-11
7. FRAME MOVEMENT METHOD AT JUMP CONVERSION.....	8-12
 <b>CHAPTER 9 TROUBLESHOOTING AND MAINTENANCE .....</b>	 <b>9-1</b>
1. REQUIRED ACTIONS AT MACHINE STOP .....	9-1
1-1. If Machine Operation is Interrupted.....	9-1
1-2. Trouble Shooting.....	9-4
2. DAILY MAINTENANCE OF THE MACHINE.....	9-6
2-1. Cleaning .....	9-6
2-2. Lubrication.....	9-8
2-3. Greasing.....	9-9
2-4. Inspections .....	9-10
2-5. Cautions in Repair.....	9-10
 <b>ELECTRICAL SYSTEM DIAGRAM .....</b>	 <b>End of this manual</b>

# 1. MACHINE INSTALLATION ENVIRONMENT

## CAUTION

- **Install the machine on a sturdy floor.**
- The floor structure must be strong enough to bear the machine weight (indicated on the spec. plate). If the floor is supported by steel frames, place the machine stand on the steel beams as long as possible.

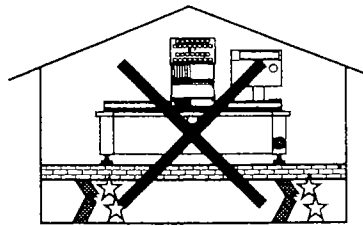

- **Prevent the operation noise in the environment.**

To improve the sound insulation performance of the factory in addition to the operation with reduced noise of this machine, use the interior finish materials which show high sound insulating performance for the walls, ceiling, and floor of the factory.

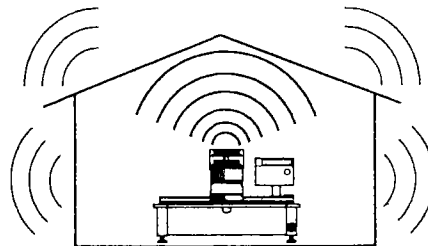

- **Avoid direct sunlight.**

If the machine is exposed to direct sunlight over an extended period, the machine body may be discolored or deformed. Put curtains or shades to the site to prevent the machine from direct sunlight.

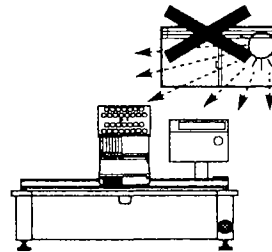

- **Avoid dust and moisture.**

Dust and moisture lead to dirt and rust on the machine. Install air conditioning equipment, and periodically clean the working area.

Use caution not to expose the machine to direct wind from the air conditioner so that the embroidery threads do not become disheveled.

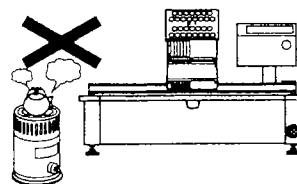

Humidity: 30 to 95%RH (relative humidity) without condensation

Ambient temperature: 5 to 40°C (during operation), -10 to 60°C (during storage)



## CAUTION







For long life machine operation, operate the machine with about 70% of the maximum speed as “operation for total fitting” for about one month after installation. By performing operation for total fitting, life of the machine will become longer, which will be useful to avoid unexpected troubles.



## WARNING

To prevent accidents resulting in injury or death and physical damage, the following items must be observed strictly when operating the machine.

### <Before Starting the Machine>

- The machine is designed and built for industrial use.
- The machine is designed and built as an industrial embroidery machine for semi- or finished textile products and similar materials. Using the machine for other purposes must be avoided. 
- Use the machine in the environment where only authorized persons are permitted to enter, so that unauthorized persons will not manipulate the machine. Especially, sufficient care must be exercised so that a child will not enter the area near the machine.
- Only the persons who are sufficiently trained for the operation must operate the machine. 
- The rear of the machine is not a working area. If you have to move to the rear of the machine, make sure to turn off the main switch. 
- Do not stand on the machine. 
- Insert the power cable plug fully. If a metallic part touches a blade in the plug, it may cause fire and/or electric shock. 
- Do not damage, modify or heat the power and other cables. Do not exert undue force to them, either. Otherwise the cables will be damaged causing fire and electric shock. 
- Read this manual and thoroughly understand the contents of operation before starting the machine.

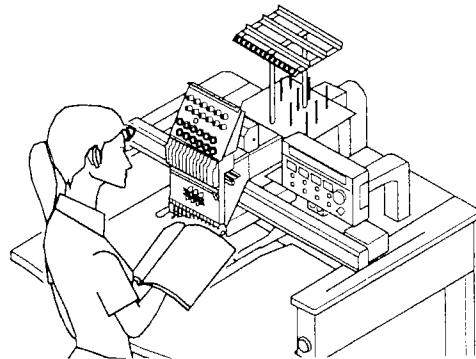



## WARNING

- Wear proper clothes and tidy up yourself so that you can smoothly perform the operation.

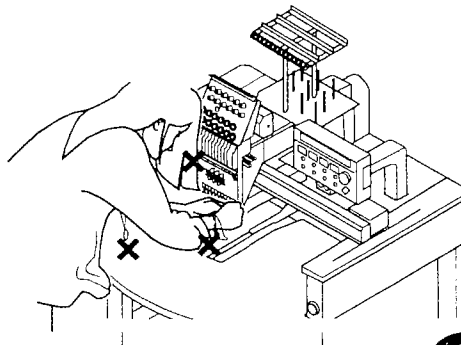

- A single operator should operate the machine in principle.
- If more than one operator are working together, make sure that no one is working near the moving parts of the machine before starting the machine.



### <During the Machine Operation>

- Keep away control units such as the power supply box and the controller box (operation panel box) from water and chemicals. Entry or splashing of them into control units leads to short circuits of internal circuits, causing fire, electric shock and other troubles.



If water or other chemicals enter a control unit, shut off the power at the primary power source and contact your Tajima distributor.

Be sure to turn off the power switch of the machine before turning off the primary power source.

- Do not use a device such as a cellular phone that generates microwave near the control circuits of the power supply box, the operation panel box, etc. Microwave may cause malfunctioning of the machine.
- Do not put your hands or face near the moving parts of the machine. Especially, the areas near moving needles, rotary hooks, take-up levers, pulleys, and speed reducing box are very dangerous.

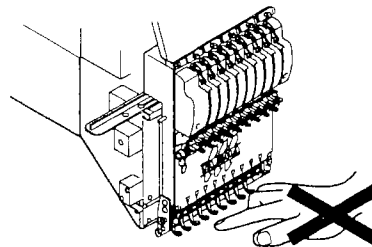

- Do not remove the covers for the shaft and the pulleys when the machine is running. Do not run the machine without the covers.



### <During Machine Adjustments>

- Turn off the primary power source before opening the electrical boxes. Be sure to turn off the power switch of the machine before turning off the primary power source.
- Stop the machine before carrying out work near the needles such as threading the needle and checking the finish of embroidery.
- Shut off the power supply by turning off the power switch before manually rotating the main shaft of the machine.





## CAUTION

<Before starting the machine>

When operating the machine, always observe the following items to prevent machine or property damage.

- Do not put things on the table.

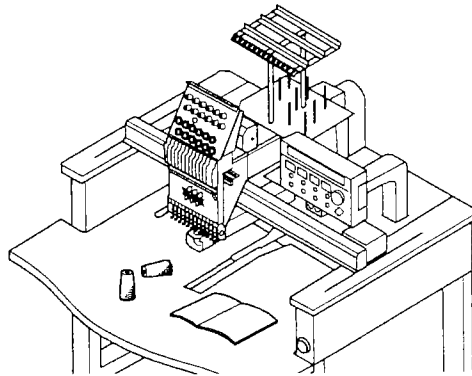

- Do not use bent needles or those that do not fit the materials.
- After the completion of work, shut off the power source by turning off the switch of the power distribution panel. Be sure to turn off the power switch of the machine before turning off the power source.



### 3. WARNING LABELS AND SPEC. PLATE

#### [IMPORTANT DIRECTIVE ITEM]

The machine has warning labels that bear instructions for safe operation. Machine operators must follow the instructions shown on the warning labels.

Do not detach these labels, nor make them illegible by painting, etc.

NOTE: If a warning label is missed or damaged, please contact your TAJIMA distributor.

#### 3-1. Positions of Warning Labels and Spec. Plate

[Front view]

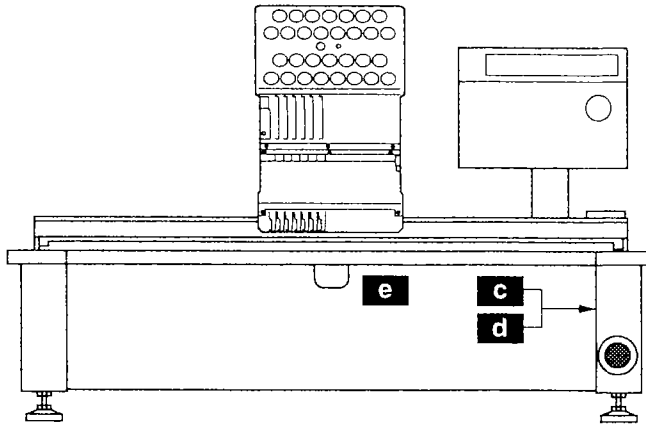

[Right view]

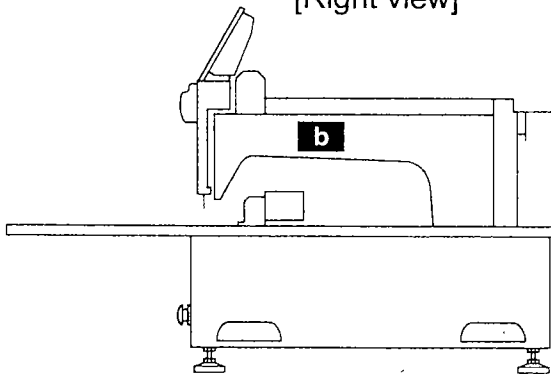

[Left view]

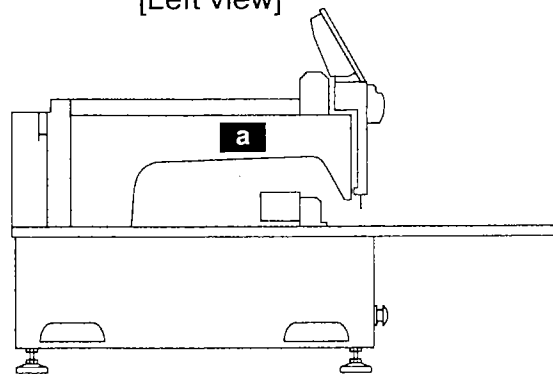

(a)

<b>⚠ WARNING ATENCION</b>	
	<b>Moving parts can cause severe injury.</b> Do not take off the safety covers nor put your hands etc. close to the moving parts during machine operation.
	<b>Las partes en movimiento pueden ocasionar lesión grave.</b> No retirar las cubiertas de seguridad ni poner las manos, etc., cerca de las piezas en movimiento mientras la máquina esté en funcionamiento.

(b)

<b>⚠ WARNING ATENCION</b>	
	<b>Exposed needles can cause severe injury.</b> Stop the machine before working near the needles.
	<b>Las agujas expuestas pueden ocasionar lesión grave.</b> Detenga la máquina antes de trabajar cerca de las agujas.

**NOTE:** The term “safety cover” used in the safety label (a) refers to all covers installed near movable units of the machine.

(c)



**HIGH VOLTAGE**

Can cause shock, burn, or death.

- ◆ The cover can be opened only by the service persons authorized by Tajima.
- ◆ When opening the cover, turn the power switch OFF and wait at least 4 minutes.

(d)

<b>⚠</b>	<b>WARNING</b> HIGH LEAKAGE CURRENT! Make sure to ground wires before connecting to the primary power supply.
<b>⚠</b>	<b>ATENCION</b> ¡ALTA FUGA DE CORRIENTE! Asegúrese de conectar con tierra los cables antes de hacerlo a la conexión principal.

(e)

MFG. NO. <u>                    </u>	
<b>仕様書 MACHINE SPEC</b>	<b>電気仕様 ELECTRICITY</b>
D (mm)	φ (mm)
SIZE W (mm)	H (mm)
H (mm)	V (mm)
NET WT (kg)	A
	V <sub>A</sub>
	W
MANUFACTURED	
<small>TOKAI INDUSTRIAL SEWING MACHINE CO., LTD. No. 1820 Utsunomiya-cho, Maunagi ARIKAWA-0501 JAPAN</small>	

## 1. FEATURES AND FUNCTIONS

- **ACCURATE FRAME DRIVING AND HIGH-SPEED CAPABILITY**

High-precision special stepping (pulse) motors perform frame driving with improved quietness and stability. The maximum main shaft speed has been increased up to 1200 rpm.

- **EASY-TO-INSTALL/REMOVE TABLE**

The sub table can be easily installed and removed so standard embroidering and embroidering on finished products can be freely performed.

- **MULTIPLE PURPOSES**

This multipurpose machine proves itself excellent power to normal embroidery, ribbon embroidery, and embroideries on finished products such as T-shirts, knitted sweaters, sweat shirts, caps, etc.

- **COMPACT BODY DESIGN**

The machine body is compactly designed and portable.

- **QUIET OPERATION**

Variety of noise-reduction mechanism keeps working environment comfortable.

- **TRACE FUNCTION**

The function checks if the design fits in the frame to be used before starting embroidery.

- **MEMORY CAPACITY**

The standard 1,140,000-stitch memory can store up to 99 designs.

- **TAKE-UP LEVER GUARD**

The take-up lever guard makes thread behavior more stable and prevents entangling and coming-off of thread.

- **ENLARGING, REDUCING, ROTATING, AND REVERSING DESIGN**

The embroidered design can be enlarged or reduced in 1% increments from 50% to 200%. The design can be rotated in 1° increments.

- **AUTOMATIC REPEAT**

By inputting the number of times the design should be repeated, the same design can be repeated up to 99 times in the X-axis and Y-axis direction independently.

- **BUILT-IN FLOPPY DISK DRIVE**

A single 2DD floppy disk can store 111 designs with approximately 240,000 stitches.

Alternatively, a 2HD floppy disk can hold 223 designs with approximately 480,000 stitches.

- **SATIN STITCH (PAT. P)**

Stitch width can be expanded in 0.1 to 1.0 mm range wider than the design data.

- **DESIGN DATA EDITING**

The design data can be edited (modified, inserted, erased, cleaned up) in 1-stitch units.

- **FRAME BACK**

The embroidery frame can be traveled back in 1/3/5-stitch units or stop code units.

- **ORIGIN RETURN**

A return to the design start point can be made during embroidery operation, even if the design start point does not coincide with the design end point.

- **AUTOMATIC THREAD TRIMMING AND HOLDING DEVICE <ATH>**

This function can automatically trim threads according to the design data commands. In manual operation, this function can trim threads as desired.

No displacement of the design occurs when power is restored after power failure, preventing loss of merchandise.

- **AUTOMATIC/MANUAL OFFSET**

The frame moves aside so that applique placement, frame changing, etc. can be done easily.

The frame can be easily returned to the original position after such operations are completed (automatic offset). Even after the frame has been moved manually during embroidering, the frame can be easily returned to the previous stitch point (manual offset).

The following indicates the electrical specifications of the machines.

Please operate your machine under the environments that satisfy these specifications.

**! CAUTION**

Usage deviated from conditions shown below may cause operation failure of the machine.

**<Power Supply>**

- Voltage/Allowable voltage fluctuation ..... 10% of the rated voltage
- Frequency..... 50/60 Hz
- Power supply capacity and power consumption..... 470VA/330W

**<Insulation Resistance>**

10M ohms or greater (measured with a 500 V insulation tester)

**! WARNING**

To avoid the danger of electric shock due to leak current, be sure to connect the grounding wire of the machine to the ground.

Grounding resistance must be 100 ohms or less.



**2-1. Switching Power Supply Specifications**

It is possible to change power supply specifications (100 V/200 V) by changing insertion of the AC power supply harness connector. It is positioned under the rear left table of the machine.

**! WARNING**

To avoid the danger of electric shock, turn OFF the primary power supply to perform the work. (Before turning OFF the primary power supply, turn OFF the power switch.)



[Ex.: When connecting to 100 V]

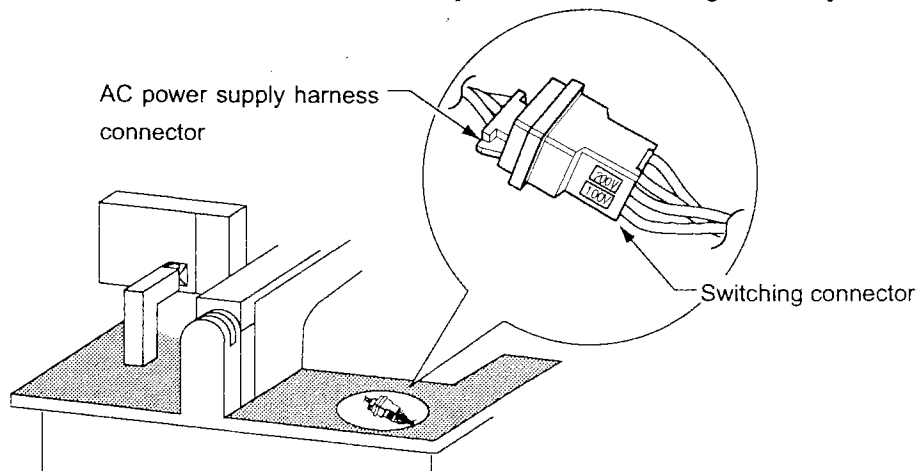

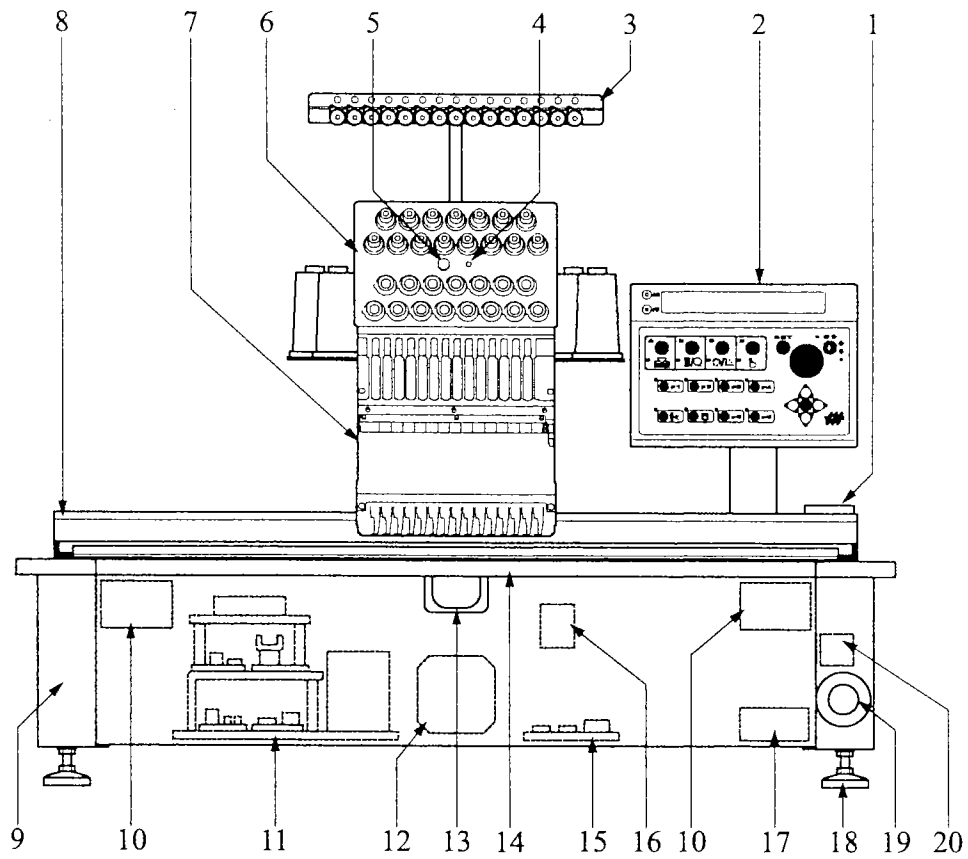

1	X-axis motor	11	Power supply/driver unit
2	Controller box	12	Main shaft motor unit
3	Thread guide system	13	Cylinder bed
4	Tension base switch	14	Table
5	Thread breakage indicator lamp	15	Joint card
6	Individual tension base	16	ATH motor
7	Needle bar case	17	Noise filter
8	Z-spec. Frame	18	Leveling adjuster
9	Stand	19	Emergency stop switch
10	Y-axis motor	20	Power switch

## 4-1. Explanation and Function of Each Part

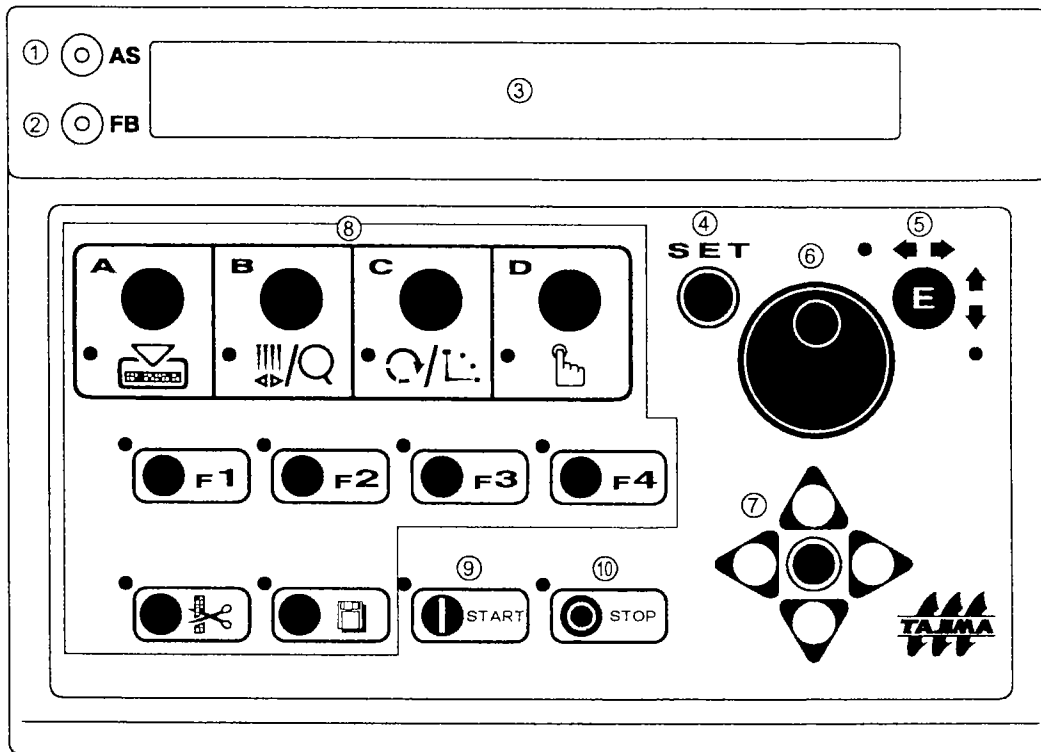

- ① Automatic/manual start setting indicator lamp

Lit: Automatic

Unlit: Manual

- ② Frame back/forward setting indicator lamp

Lit: Back

Unlit: Forward

- ③ Display screen

The screen displays guide messages for setting the data and the present settings.

- ④ SET key

Press this key after inputting each setting item or when selecting a setting item.

**NOTE:** This key is also used as the reset key when an error code number is displayed.

- ⑤ Manual frame travel mode key

Press this key to switch to the manual frame travel mode and use jog dial to travel the frame manually. To exit the manual frame mode, press any operation key.

**NOTE 1:** For details of manual frame travel mode, refer to p.4-9.

**NOTE 2:** By using this key while in the parameter setting mode, the input value can be reset to the previous set value and the display mode can be returned to the "Normal Display".

⑥ Jog dial/shuttle

The jog dial/jog shuttle provide the following two functions.

- Selection of an input value

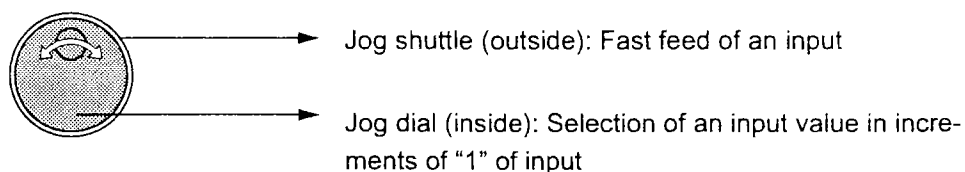

Example of input value selection (selection range: 0 to 5)

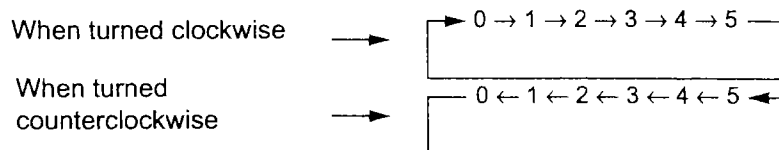

- Manual feed of an embroidery frame

**NOTE: For details, refer to p.4-9.**

⑦ Manual frame travel keys

Used for manually moving the embroidery frame.

**NOTE: For details, refer to p.4-8.**

⑧ Setting keys

Used to call a variety of functions and operations.

⑨ Start switch

Pressing this switch starts the machine.

**NOTE: For details, refer to p.2-2.**

⑩ Stop switch





Pressing this switch stops the machine.



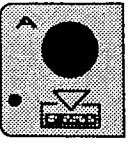
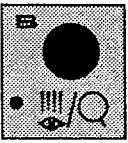
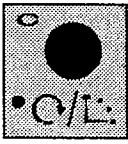
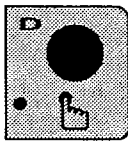

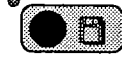

**NOTE: For details, refer to p.2-2.**

#### 4-2-1. Functions of Menu Keys

Functions and operations that can be called by each setting key on the operation panel are collected as a table shown below. For details of each function and operation, refer to the chapter 3 to the chapter 7.

Menu key	Screen Number	Function	Page
	1	Data Input (Memory)	p.3-1
	2	Data Input (FD)	p.3-3
	4	Data Input (Serial)	p.3-5
	5	Memory Delete	p.3-7
	1	Automatic Color Change / Automatic Start	p.6-17
	2	Needle Bar Selection	p.6-19
	3	Data Conversion	p.6-42
	4	Repeat	p.6-25
	5	Automatic Offset	p.6-30
	6	Automatic Start after Automatic Data Set	p.6-35
	1	Maximum RPM	p.5-1
	2	Total Stitch Counter / Design Timer	p.4-18
	3	Frame Back/Forward Operation in Stop Code Units, by Designated Number of Stitches	p.4-10
		Frame Back / Forward	p.5-12
	4	Automatic Origin Return	p.6-36
	5	Preset Halt	p.6-37
	1	Manual Color Change	p.4-1
	2	Manual Thread Trimming	p.4-3
	3	Manual Origin Return	p.4-4
	4	Manual Offset	p.4-5
	5	Trace	p.4-6

Function Key	Screen Number	Function	Page	
	1	Jump Conversion	p.6-45	
	2	Automatic Jump	p.6-47	
	3	Satin Stitch	p.6-48	
	5	Backlash	p.6-49	
	1	Low Speed RPM	p.5-3	
	2	Number of Start Inching Times	p.5-7	
	3	Pseudo-fixed Position Stop	p.6-40	
	4	Frame Travel Speed	p.5-11	
	5	Upper Thread Breakage Detection	p.6-1	
	6	Under Thread Breakage Detection (Detecting Method)	p.6-5	
	7	Under Thread Breakage Detection (Movement Ratio)	p.6-9	
	1	Automatic Thread Trimming	p.6-13	
	2	Under thread trimming selection	p.7-8	
	4	Boring Device	p.7-1	
	6	Cording Device	p.7-3	
	7	Auto Ribbon Feeding Device	p.7-6	
		1	Network	p.7-4
			1	Data Edit (Modify)
2			Data Edit (Insert)	p.3-17
3			Data Edit (Delete)	p.3-23
4			Data Edit (Cleanup)	p.3-28
	1	Floppy Disk Processing (Save)	p.3-30	
	2	Floppy Disk Processing (Delete)	p.3-34	
	3	Floppy Disk Processing (Format)	p.3-36	

Function Key	Screen Number	Function	Page
 + 	—	Confirmation Mode	p.4-20
 + 	1	Max. RPM Limit	p.5-5
	2	Frame Drive Start Timing	p.5-9
	3	ATH Drive Start Timing	p.5-16
 + 	1	Power Resume	p.4-15
	2	Frame Origin Memory	p.4-13

<Right Side of the Controller Box>

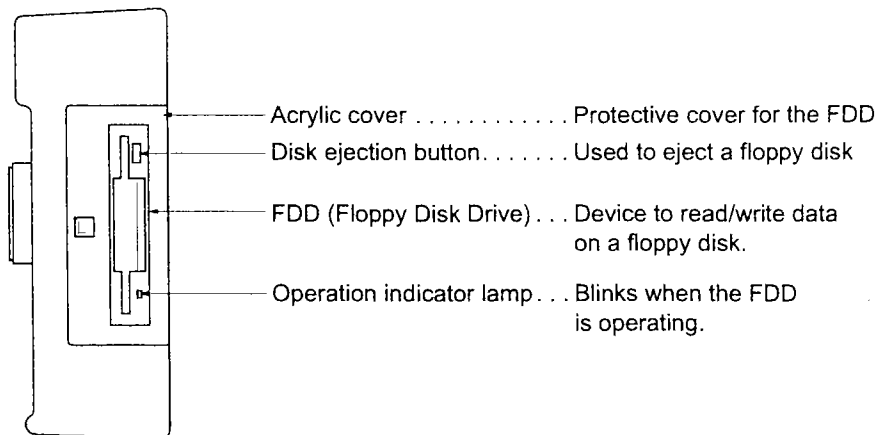

<Bottom of the Controller Box>

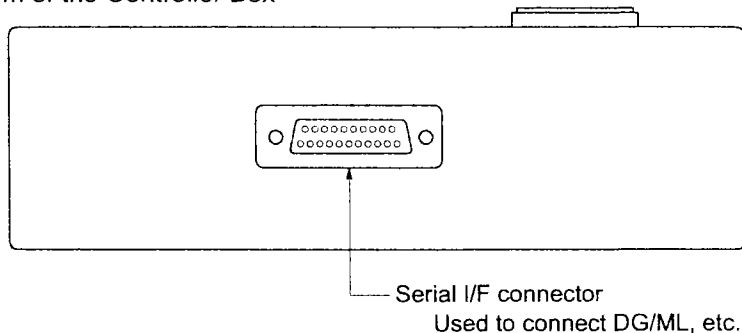

## ! CAUTION

**When changing dip switch setting, be sure to turn OFF the power. Dip switch setting will be effective when the power is turned ON next.**

**[NOTE]** For communications through the series interface, 38,400 bps is set as the initial value for communication speed. If communication speed other than 38,400 bps is desired, set the DIP switch (SW1) on the CPU card according to the desired speed. For the DIP switch setting procedure, please contact TAJIMA's distributor.

SW1-1	SW1-2	Communication speed
OFF	OFF	9,600 bps
ON	OFF	19,200 bps
OFF	ON	9,600 bps
ON	ON	38,400 bps

**NOTE:** SW1-3: must always be OFF  
SW1-4: must always be OFF

<Rear of the Controller Box>

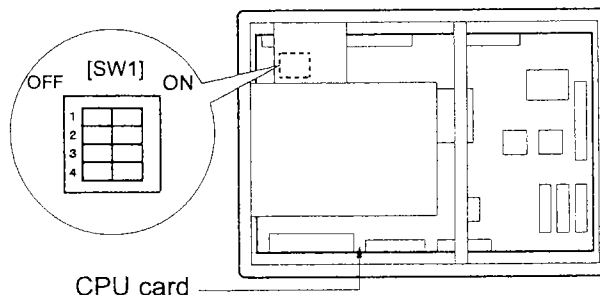

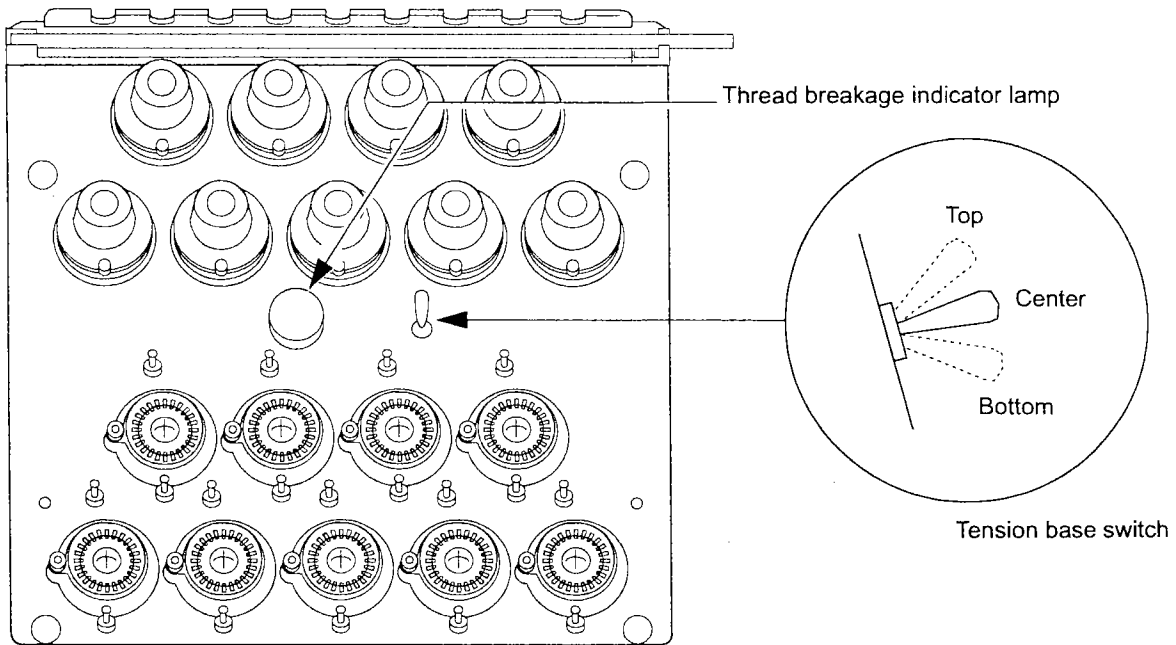

#### <Function of the Tension Base Switch>

- [Center] position (normal operation) Switch  
 During normal embroidering operation, the switch must be kept in the "center" position.  
 If the machine stops due to the detection of thread breakage, travel the frame back to the thread broken position then restart the machine and embroidery restarts from the position where the machine is restarted.

**NOTE:** To start embroidery from the position where the frame has traveled back in status without detection of thread breakage, push the tension base switch up to the "top" position once and release it. The return spring automatically returns the switch to the "center" position when the switch is released.

- [Bottom] position (holding needle bars)  
 When the switch is pushed down to the "bottom" position, the needle bar in the head does not move. (Embroidery is not performed.)

#### <Function of the Thread Breakage Indicator Lamp>

- During normal operation ..... Green (lit)
- When upper thread breakage is detected..... Red (lit)
- When under thread breakage is detected..... Red (blinking)



## CAUTION

Do not block wind flow of cooling fans.

If the cooling wind flow is blocked, devices in the power supply/driver unit are overheated, causing machine malfunction.

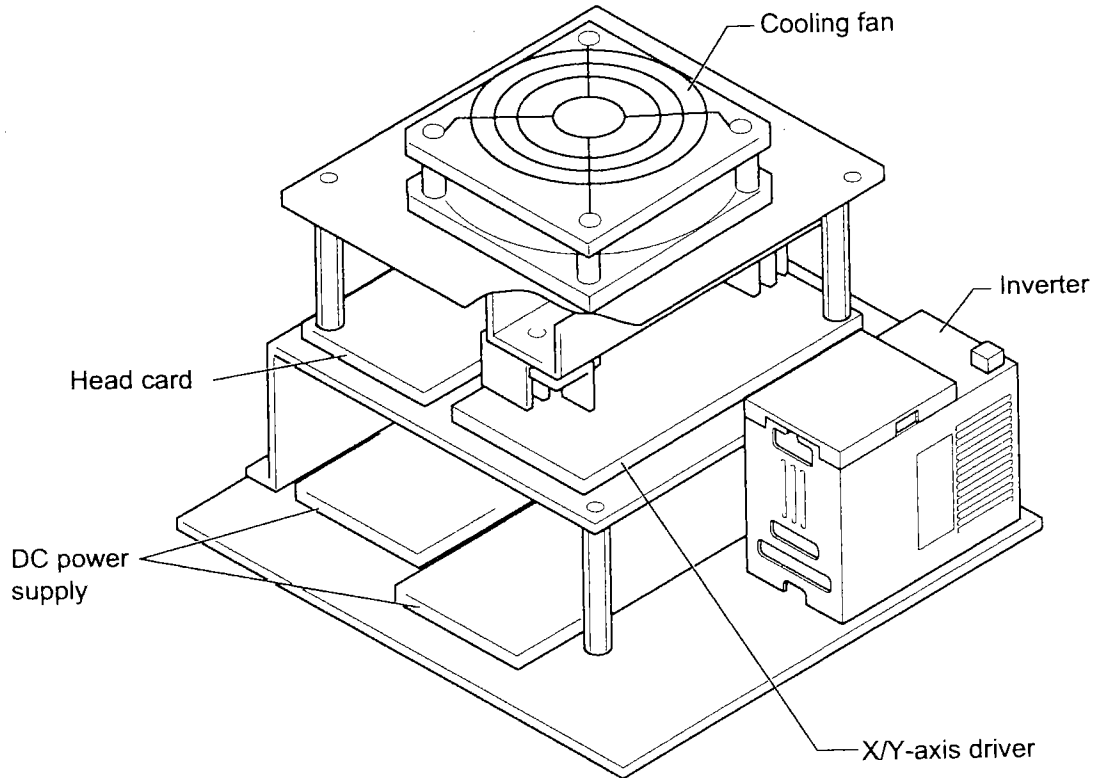

Setting for dip switches on the Head Card and the X/Y-axis Driver are indicated below.

# CAUTION

Do not change the dip switch settings.

The machine may malfunction to cause physical damage such as breakage of the machine.



[Head card]

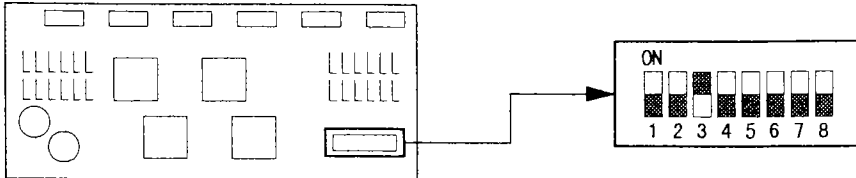

[X/Y-axis driver]

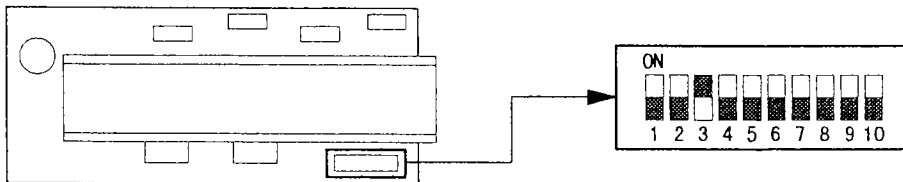



# 1. STARTING AND STOPPING THE MACHINE

## 1-1. Power Switch

The power switch is provided at the front of the right side stand (p.1-4).

## 1-2. Emergency Stop Switch

 <b>CAUTION</b>
When restart the machine after stopping it by the emergency stop switch, pay attention to the safety of the surroundings. 

Use the emergency stop switch to stop the machine in an emergency. Pressing the emergency stop switch stops the machine, and the code number 2CE will be displayed. To restart the machine, press the set switch and then press the start switch.

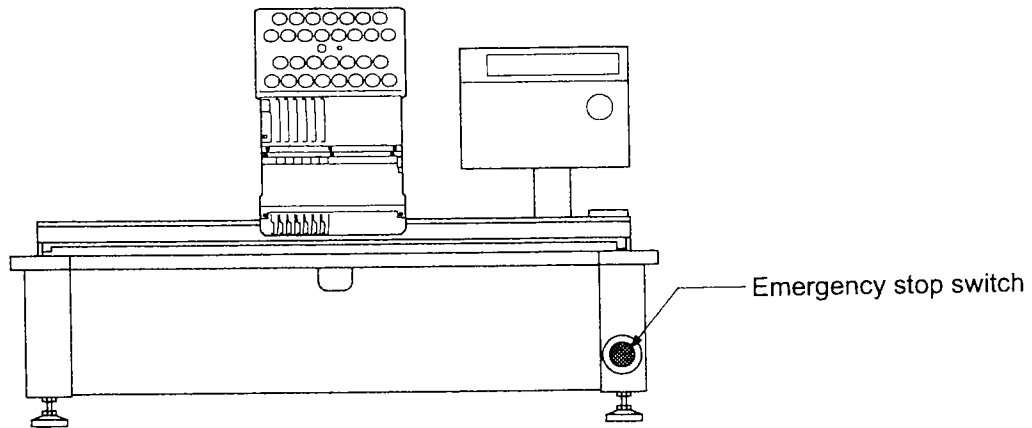





## ⚠ WARNING

Even if machine stop operation by bar switch or stop switch is performed, the machine may not stop immediately to avoid design displacement. Do not bring your hands or face close to the needle or moving parts such as take-up lever until you confirm the machine stops completely.

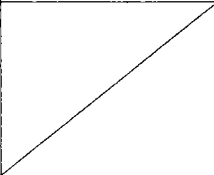

The machine is started or stopped by the operation of the start and stop switches.

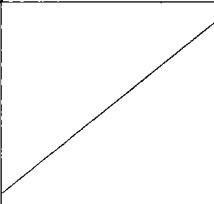
How the machine behaves according to the operation of the start/stop switch will vary according to the machine status (while the machine is stopped or running) as shown below.

Machine status Operation	Stopped	Running
Press and release the start switch. 	The machine starts operating.	
Press the start switch and hold it pressed. 	The machine starts operating (keeps inching mode). ↓ Release the switch. ↓ Usual operation starts.	
Press and release the stop switch. 	Frame back (FB)/frame forward (FF) by set unit will be performed (p.5-12).	The machine stops.
Press the stop switch and hold it pressed. 	FB/FF by set unit will be performed (p.5-12). <b>&lt;When releasing the stop switch within 10 frame feeds&gt;</b> The machine will stop FB / FF at the point where the stop switch is released. <hr/> <b>&lt;When releasing the stop switch with 11 frame feeds and more&gt;</b> FB/FF continues. It is possible to change the speed (*1) of FB/FF during continuation (Equivalent to 250 - 1200 rpm). ↓ To stop the frame back/frame forward motion, push the stop switch again.	The machine stops.

\*1: It is displayed with rpm converted into main shaft rotating speed (\*2). Actual speed varies depending on stitch length.

\*2: The initial set value is 1000 (rpm). If frame back/forward is executed again after stopping it once, the speed setting will return to the initial value.

## 2-1. Precautions on Handling Floppy Disks and Floppy Disk Drive (FDD)

**NOTE:** It is recommended to use TAJIMA disks.  
When using a floppy disk sold in the market, format it (p.3-36) before use.





### CAUTION

Observe the items indicated below when handling floppy disks.

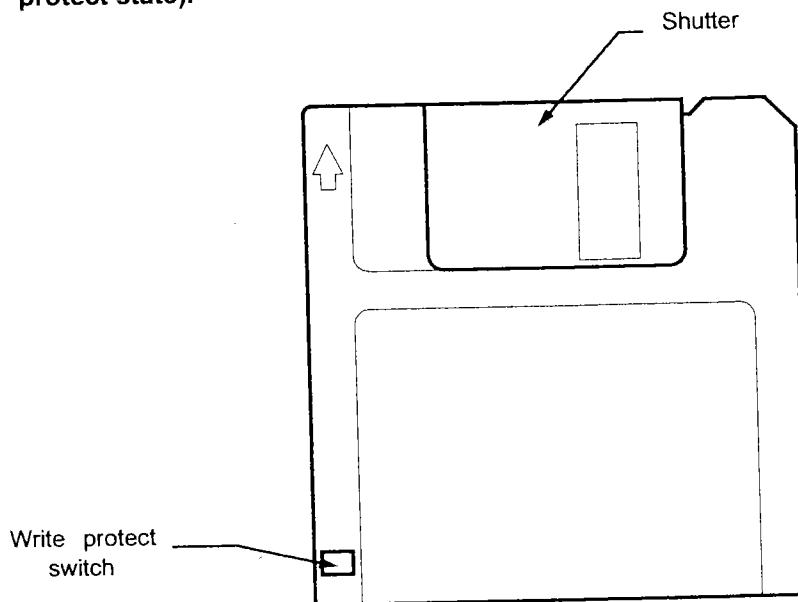
- Do not put the floppy disk near magnets or objects such as a TV set which generate magnetic field.
- Do not expose the floppy disk to excessive heat, humidity, or direct sunlight.
- Do not place heavy objects on the floppy disk.
- Floppy disks do not last eternally. Data must be copied to backup floppy disks for storage.
- Do not use damaged or deformed floppy disk, otherwise the floppy disk drive could be damaged.
- Clean the head of floppy disk drive regularly (about once a month) using a cleaning disk on the market, otherwise read/write could be faulty.
- Do not open the shutter.
- To prevent the stored data from being erased, slide the tab of the write protect switch to open the write protect window of a floppy disk (write protect state).



# ! CAUTION

- Insert a floppy disk slowly and carefully into the floppy disk drive. If a floppy disk is inserted impetuously, pressing the eject button may fail to eject the floppy disk. This could cause the floppy disk to be damaged and, in addition, the floppy disk drive could be damaged. 
- Do not forcibly remove floppy disk from the floppy disk drive. If the floppy disk is forced out of the floppy disk drive, the floppy disk and the floppy disk drive could be damaged. 
- Do not try to remove the floppy disk while the floppy disk drive is operating (The operation indicator lamp is lighting). The contents in the floppy disk could be destroyed. 

## <Insertion>

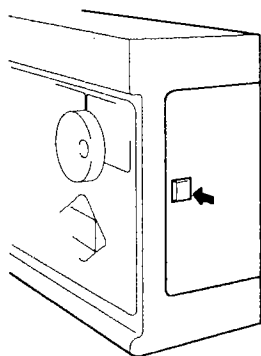

Press the acrylic cover at the point marked by the arrow to open it.

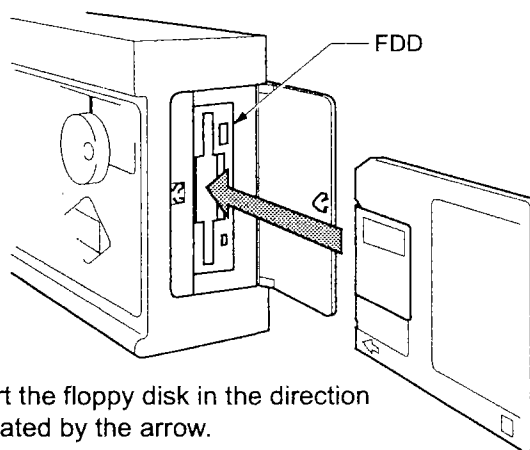
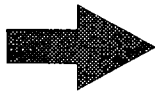

Insert the floppy disk in the direction indicated by the arrow.

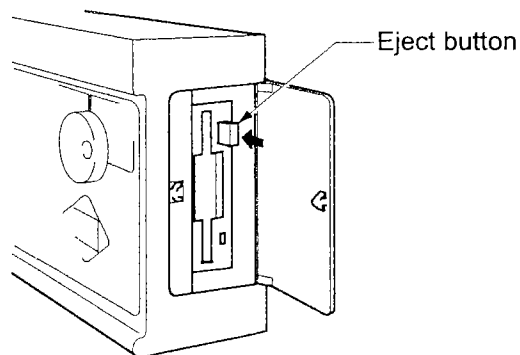
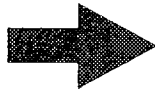
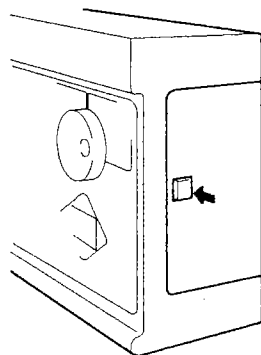

## <Removal>



Push the eject button indicated by the arrow to eject the floppy disk from the floppy disk drive.

This is the operation to install the software to the machine. Perform installation in the following cases.

- When setting up the machine or upgrading the version
- When remodeling the machine for attaching the auto ribbon feeding device after purchasing the machine

 <b>CAUTION</b>	
<ul style="list-style-type: none"><li>• When the software is installed, all design data currently stored in memory are erased. Do not forget to save the necessary design data in floppy disks before installing the software.</li><li>• Select the models that corresponds to the specifications in "7. Set the model." (p.2-8). If a wrong model is selected, troubles such as damage of cards, etc. may occur.</li></ul>	 

**NOTE:** For the operation to save the design data in floppy disk, refer to "Floppy Disk Processing (Save)" on p.3-30.

### 3-1. Procedure

1. Turn OFF the power switch.

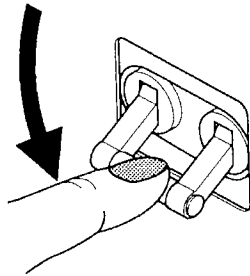

2. Insert the software floppy disk in the FDD.

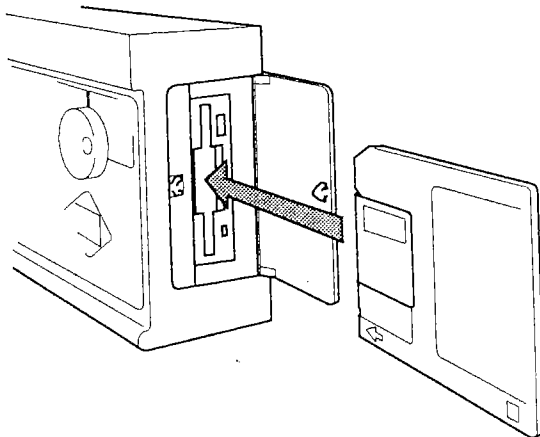

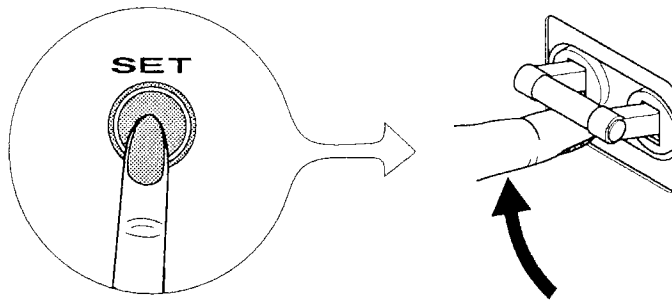

Keep the SET key pressing after turning the power switch ON.

The following message appears on the screen. Keep on pressing the SET key.



- When the LED indicator in the Menu Key A lights, release the SET key and press the Function Key 3.

**NOTE:** Keep on pressing the Function Key 3 until software installation is completed.

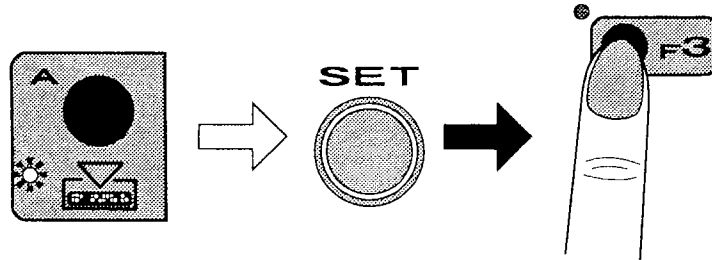

Software installation proceeds.

The LED indicators of Menu Keys A to D light in order as software installation proceeds.

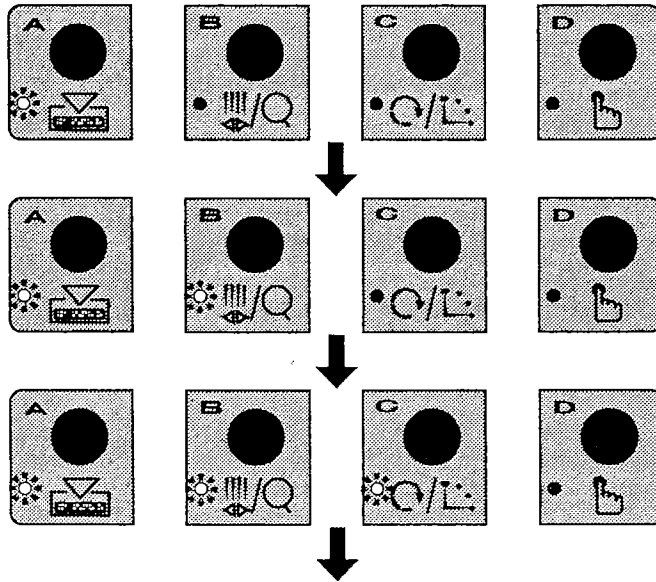

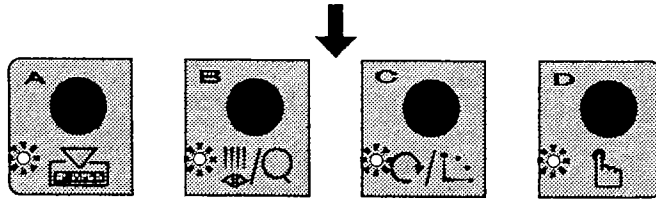

On completion of software installation, all the LED indicators of Menu Keys A to D are lit. At the same time, the following message is displayed.

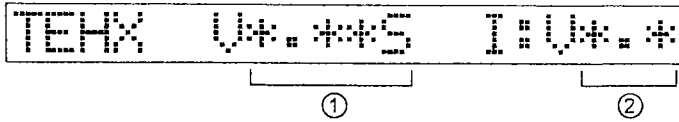

- ① Software version number
- ② ROM version number

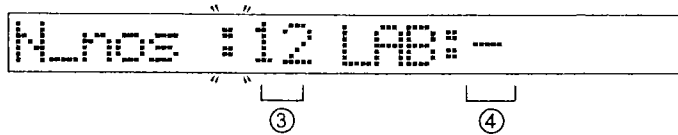

- ③ Number of needles per head
- ④ Machine corresponding to auto ribbon feeding device/Non-corresponding machine

5. When the installation of software is completed and the above message is displayed, release the Function Key 3.

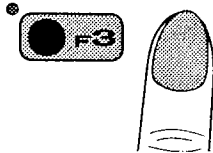

6. Set the number of needles per head.



Select the number of needles per head. [Example: 15 (Needles)]

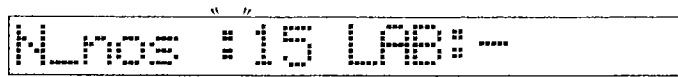

**SET**



Press the [SET] key to decide the selection of number of needles.



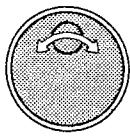

Select the model.

**NOTE:** Select "O: Model corresponding to the auto ribbon feeding device" when the machine was shipped with the device as the option whether the auto ribbon feeding device is to be used or not, or remodeling the machine for attaching the device to the machine. If not, select "—: Model not corresponding to the auto ribbon feeding device".

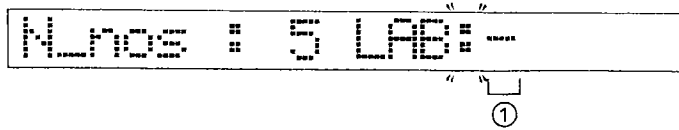

① Model corresponding to the auto ribbon feeding device: O  
Model not corresponding to the auto ribbon feeding device: —

[Example: "O: Model corresponding to the auto ribbon feeding device"]



**SET**



Press the [SET] key to decide the model selection. (The screen will return to the normal display.)



Actual screen display differs depending on setting contents.

8. Remove the software floppy disk from the FDD.

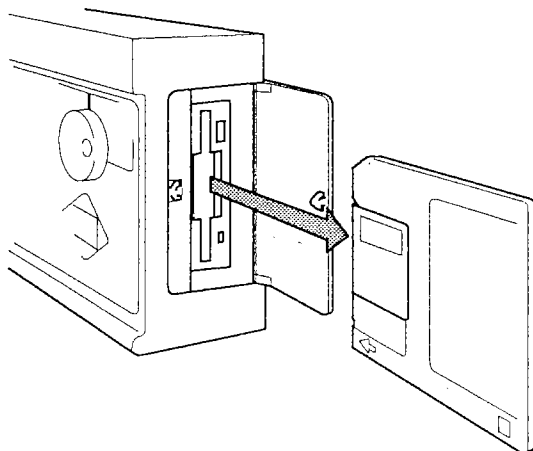

**NOTE 1:** Perform "Frame Origin Memory" operation (p.4-13) continuously.

**NOTE 2:** When software installation is performed, each setting value will return to the initial value. Change it if necessary.

The display screen on the operation panel displays a variety of messages and information according to the status of the machine.

#### 4-1. Display after Turning the Power ON

When the power switch is turned ON, the software executes a self check and the following message is displayed while self check is executed.

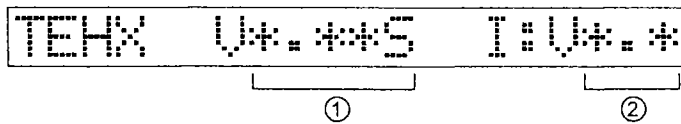

- ① Software version number
- ② ROM version number

#### 4-2. Normal Display

After the completion of software self check, the display changes to the normal display.

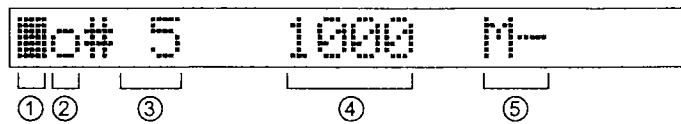

- ① Fixed position display: This symbol is displayed when the machine stops at the fixed position.
- ② Offset setting display:
  - “0” .....Automatic offset is “Set”.
  - No display .....Automatic offset is “Not Set”.
- ③ Needle position display: ..... Presently selected needle bar number is displayed.
- ④ RPM display: Presently set maximum rpm (p.5-1) is displayed.
- ⑤ Data input complete/incomplete state display:
  - “M-” .....Design data unregistered status
  - “M?” .....Data input incomplete status
  - “M\*\*\*” .....Data input complete status (“\*\*\*”: Design data No.)

#### 4-3. Display during Operation

The screen display will become as shown below during operation.

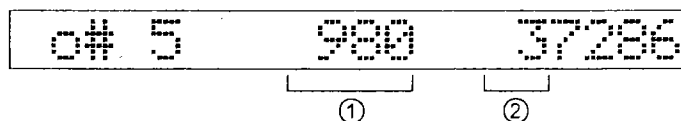

- ① Display of actual speed (rpm): Actual speed during operation is displayed (\*1).
- ② Stitch counter (per design)

\*1: It is possible to change the setting for maximum speed during operation by turning the jog dial. If you turn the jog dial while the machine is running, the actual speed also varies as the maximum speed is changed. While the jog dial is turned, the maximum speed is displayed in this area in parentheses “Ex: (1000)” and if you stop turning the jog dial, the display returns to the actual speed display.

Before starting embroidering, be sure to inspect the following items. If an abnormality is found in the inspections, take the specified corrective measures.

**NOTE:** If the measures to be taken are not clear, please contact TAJIMA's distributor.



## WARNING

Turn the power switch OFF before carrying out pre-operation inspection. If the inspections are carried out with the power on, there is a danger that you sustain severe injuries by becoming entangled with the machine or being stabbed with needles.



### [Inspections and Corrective Measures]

Inspection	Corrective Measures
Installation of covers.	Install all covers to the machine at correct positions.
Setting of embroidery thread	Set embroidery thread correctly.
Break and bent of needles	Change the defective needles.
Lubricated conditions of rotary hook etc.	Supply lubricating oil if necessary.

The following flowchart shows basic operation procedure to be followed before starting embroidery.

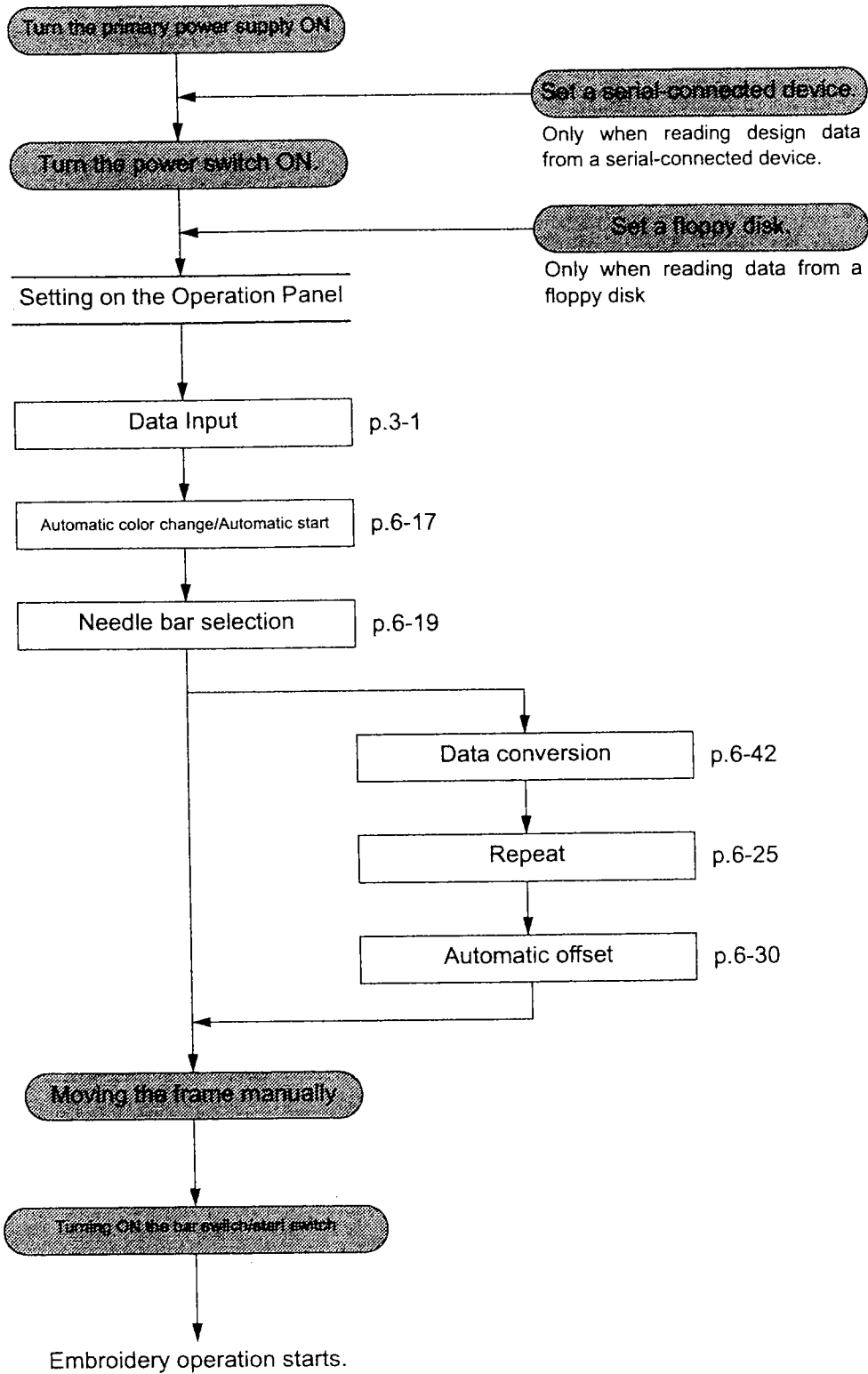

■: Setting and operation that can be made even during embroidery. (\*1).

□: Setting and operation that cannot be made during embroidery.

\*1: The state in which the machine is stopped after sewing a stitch or performing frame forward after data input.

	Setting Item	Outline	Page
■	Data input	Operation to input design data from memory, FDD, or serial-connected device	p.3-1
□	Memory delete	Operation to delete design data stored in memory	p.3-7
■	Automatic color change/ automatic start	Setting to decide whether or not automatic color change/ automatic start is performed according to setting for needle bar selection	p.6-17
■	Needle bar selection	Setting for sequence of needle bars to be used (required for automatic color change)	p.6-19
□	Data conversion	Setting to reduce, enlarge, rotate, and reverse a design.	p.6-42
□	Repeat	Setting to embroider the same design repeatedly	p.6-25
□	Automatic offset	Setting to move the frame toward the operator when embroi- dery is finished	p.6-30
□	Automatic start after automatic data set	Setting to embroider the design of which data has been set repeatedly from the same position.	p.6-35
■	Maximum rpm	Setting for the maximum rpm of the main shaft	p.5-1
■	Total stitch counter/ design timer	Operation to display the total number of stitches so far and embroidering time of a design	p.4-18
■	Frame back/forward (FB/ FF)	Setting to select operation to execute FB/FF in stop code units, designated number of stitches	p.4-10
		Setting to select operation to execute frame back/forward and frame feed unit	p.5-12
■	Automatic origin return	Setting to return the frame automatically to the design start position when embroidery is finished	p.6-36
■	Preset halt	Setting to make the machine stop automatically	p.6-37
■	Manual color change	Operation to select needle bar(s) manually	p.4-1
■	Manual thread trimming	Operation to trim thread manually	p.4-3
■	Manual origin return	Operation to return the frame to the design original point manually	p.4-4
■	Manual offset	Operation to return the frame to the original position when moving the frame by manual frame travelling or manual origin return during embroidery	p.4-5
□	Trace	Operation to move the frame according to the maximum embroidery range of the set design data	p.4-6
■	Manual frame travelling	Operation to move the frame manually	p.4-7
■	Jump conversion	Setting to convert jump code to frame stepping code and for the frame travelling method for frame stepping	p.6-45



■	Automatic jump	Setting to perform automatic jump	p.6-47
■	Satin stitch	Setting to extend the satin stitch width	p.6-48
■	Backlash	Setting to correct errors generated by backlash of X/Y-axis drive system when polarity of design data is reversed	p.6-49
■	Low speed rpm	Setting for the lowest rpm of the main shaft	p.5-3
■	Number of start inching times	Setting for the number of inching times at start	p.5-7
■	Frame travel speed	Setting for the frame travel speed for origin return, offset feed, etc.	p.5-11
■	Upper thread breakage detection	Setting for the upper thread breakage detection method	p.6-1
■	Automatic thread trimming	Setting to decide whether or not the ATH operates and the action when it operates	p.6-13
■	Max. rpm limit	Setting for the maximum rpm of the main shaft	p.5-5
■	Frame drive start timing	Setting for the frame drive start timing	p.5-9
■	Frame origin memory	Operation to make the machine to memorize the frame limit within an embroidery range	p.4-13
□	Data edit (modify, insert, delete) (*1)	Operation to modify, insert, and delete stitch data, function code, etc. of design stored in memory	p.3-11 p.3-17 p.3-23
□	Data edit (cleanup)	Operation to clean up stitch data of a design registered in memory	p.3-28
■	Floppy disk processing	Operation to write data stored in memory to a floppy disk, to deleted a design from a floppy disk, and to format a floppy disk.	p.3-30
■	Confirmation mode	Operation to confirm the current settings. * The confirmation in confirmation mode is enabled only in the normal display state	p.4-20
■	Power resume	Operation to avoid design displacement caused by power failure during embroidery	p.4-15
■	Under thread breakage detection	Setting for the under thread breakage detection method	p.6-5 p.6-9
□	Boring device	Setting to decide whether or not boring is performed, and for the data processing method for boring (option)	p.7-1
□	Cording device	Setting to decide whether or not cording is performed (option)	p.7-3
□	Auto ribbon feeding device	Setting to use the auto ribbon feeding device (option)	p.7-6
■	Network	Setting to decide whether or not network connection is made (option)	p.7-4

\*1: Design data can be edited even when the design is being embroidered.

# 1. DATA INPUT

## 1-1. Data Input (Memory)

The data input (memory) operation calls the design data stored in memory to use it for embroidery.

Menu Key	Screen Number
	

### <Setting and Screen Display>

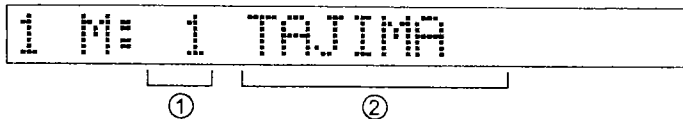

① Design data number

② Design name (\*1)

\* 1: Design name is displayed only when a design name is assigned to the design data.  
Design name of up to 8 characters may be displayed.

### <Required Setting Item>

Setting Item	Setting Range
Design data number.	1 to 99

### 1-1-1. Procedure

1. Select the Data Input (Memory) function.

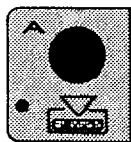

Press the Menu Key A to display the screen as shown below.



① Displays the smallest design data number among the design data numbers registered in memory.

2. Select the desired design data number.

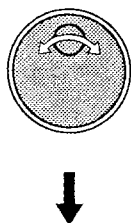

Select design data number by turning the jog dial [Ex.: 5].

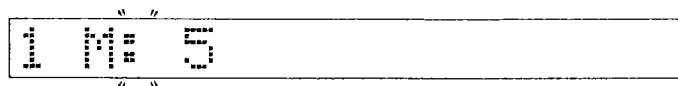



Press the [SET] key to decide the selection.

On completion of the calling of the design data, the screen returns to the normal display (p.2-9).

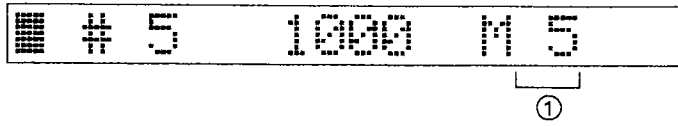

① Displays the selected design data number.

**NOTE:** Actual display differs depending on the setting contents.

## 1-2. Data Input (Floppy Disk)

This operation loads the design data from floppy disk (FD) to memory through the built-in floppy disk drive (FDD) and store it in memory to make embroidery possible.

Menu Key	Screen Number
	2

### <Setting and Screen Display>

- When selecting design data number of floppy disk

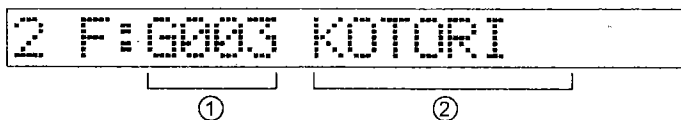

① Design data number

② Design name (\*1)

- When selecting design data number of memory

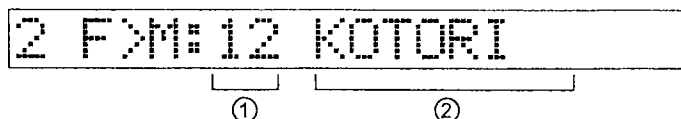

① Design data number

② Design name (\*1)

\* 1: Design name is displayed only when a design name is assigned to the design data. Design name of up to 8 characters may be displayed.

### <Required Setting Items>

Setting Item	Setting Range
Design data number (FD)	2DD: 1 to 111, 2HD: 1 to 223
Design data number (memory)	1 to 99

### 1-2-1. Procedure

1. Select the Data Input (FD) function.

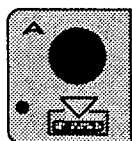

Press the Menu Key A to display screen as shown below.



**SET**



Press the [SET] Key to decide "Data Input (FD)".

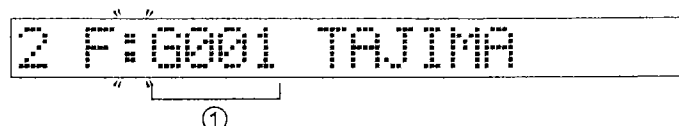

- ① Displays the smallest design number among the design numbers registered in floppy disk.

2. Select the design data number of the design to be loaded from floppy disk to memory.



**SET**



Select design data number by turning the jog dial [Ex.: G003]

2 F:G003 KOTORI

Press the [SET] key to decide the selection.

2 F>M: 7 KOTORI

①

②

① Displays the smallest number among nonregistered design data numbers.

② Displays the design name registered in memory.

3. Select the design data number to be registered in memory.



**SET**

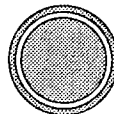

Select the design data number by turning the jog dial [Ex.: 12].

2 F>M: 12 KOTORI

Press the [SET] key to decide the selection.

On completion of registering the data to memory, the screen returns to the "normal display" (p.2-9).



# 5 1000 M12

①

① Displays the selected design data number.

**NOTE:** Actual display differs depending on the setting contents.

This operation inputs the design data from the serial-connected device (DG/ML, etc.) to memory to make embroidery possible.

Menu Key	Screen Number
	

## CAUTION

Turn **ON** the power of the machine before sending data from the device connected to the serial connector. If turning **ON** the power of the machine after data sending operation, data is not sent correctly and embroidery will be troubled.



### <Setting and Screen Display>

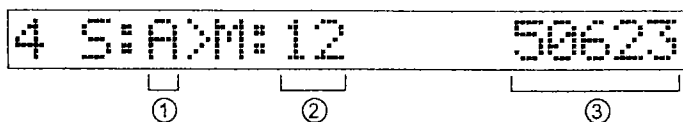

- ① Code format of the design data to be read
- ② Design data number (memory)
- ③ Remaining memory capacity (\*1)

\* 1: The maximum memory capacity at present is 1,140,000 stitches.

### <Required Setting Items>

Setting Item	Setting Range
Code format	A (Automatic recognition), T (Tajima), B (Barudan), Z (ZSK)
Design data number (memory)	1 to 99

**NOTE:** Devices that can be connected to the serial connector are indicated below.

- 8RP (8-bit reader & punch)
- DG/ML (Punching & lettering editing system)

1. Select the data Input (Serial) function.

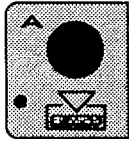

Press the Menu Key A to display screen title as shown below.

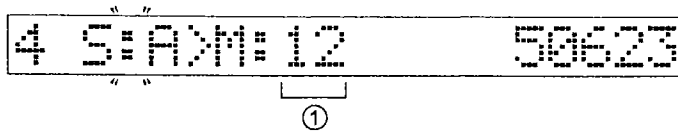

① Displays the smallest design data number among the nonregistered design data numbers in the memory.

2. Select the design data code format to be read.



**SET**



Select code format by turning the jog dial [Ex.: T (TAJIMA)].



Press the [SET] key to decide the selection.



3. Select the design data number of memory for registering the design data.

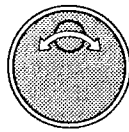

**SET**



Select design data number by turning the jog dial [Ex.: 18].

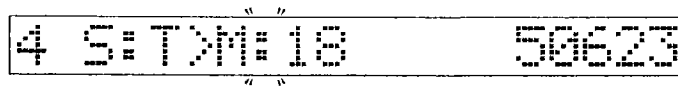

Press the [SET] key to decide the selection.

On completion of registering the data to memory, the screen returns to the "normal display" (p.2-9).



① Displays the selected design data number.

**NOTE:** Actual display differs depending on the setting contents.

## 2. MEMORY DELETE

### 2-1. Memory Delete

The memory delete operation deletes design data stored in memory.

For deleting memory stored designs, two modes of operation as indicated below are available.

Menu Key	Screen Number
	5

- Deleting the selected design data
- Deleting all design data stored in memory

**NOTE:** It is not allowed to delete the memory until the machine finishes embroidery.

#### <Setting and Screen Display>

**NOTE:** When selecting “Memory Delete”, the alarm will sound.

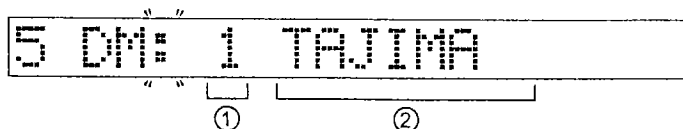

Display changes alternately (only when deleting the selected design data).

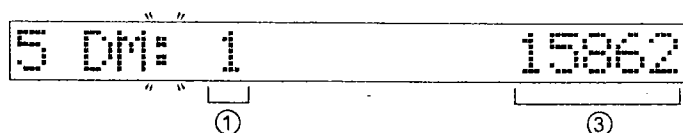

- ① Design data number (\*1)

\* 1: "00" is displayed if the "all design data delete" mode is selected.

- ② Design name (\*2)

\* 2: Design name is displayed only when a design name is assigned to the design data. However, no display is made when "all data delete" is selected.

- ③ Data size (number of stitches) of the selected design (\*3)

\* 3: No display is made when "all data delete" is selected.

#### <Required Setting Item>

Setting Item	Setting Range
Design data number (memory)	1 to 99 (for deleting only the selected design data) 00 (for deleting all memory registered design data)

1. Select the Memory Delete function.

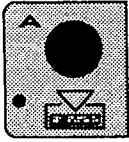

Press the Menu Key A to display screen title as shown below.



Display changes alternately.

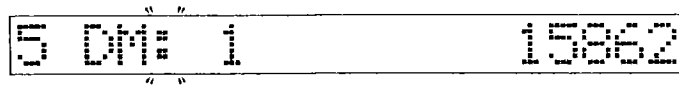

- ① Displays the smallest design number among the design numbers registered in memory.

**NOTE:** When selecting "Memory Delete", the alarm will sound.

2. Select the mode of memory delete operation.

**<Deleting only the selected design data>**



Select design data number to be deleted [Ex.: 18].



**SET**



Press the [SET] key to decide the selection.

On completion of data deletion, the screen as shown below will be displayed.

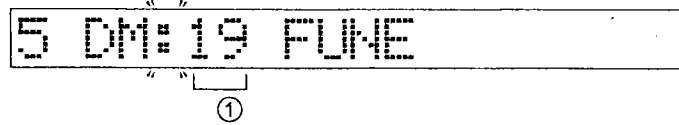

Display switches alternately.

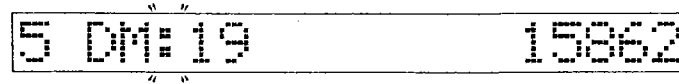

- ① Displays the next design number to the design number that has been deleted among the design numbers registered in memory.

**NOTE:** When performing other setting(s)/operation(s), press the corresponding menu key(s)/function key(s).

When pressing the  key, the screen returns to the "normal display" (p.2-9).



Select "00" by turning the jog dial.

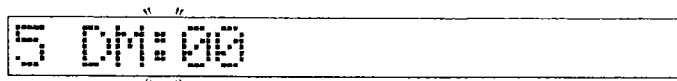

**SET**



Press the [SET] key to decide the selection.

On completion of data deletion, the screen as shown below will be displayed.

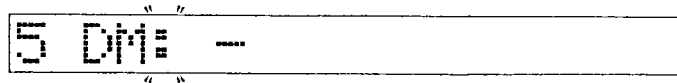



**NOTE:** When performing other setting(s)/operation(s), press the corresponding menu key(s)/function key(s).

When pressing the  key, the screen returns to the "normal display" (p.2-9).

### 3-1. Data Edit (Modify)

The data edit (modify) operation modifies the design data registered in memory.

Modification of design data is possible in one stitch unit and the search function can be used for locating the stitch for which the data should be modified.

Menu Key	Screen Number
	

#### <Setting and Screen Display>

- When selecting design data number



① Design data number

② Design name (\*1)

\* 1: Design name is displayed only when a design name is assigned to the design data.

- When editing design data

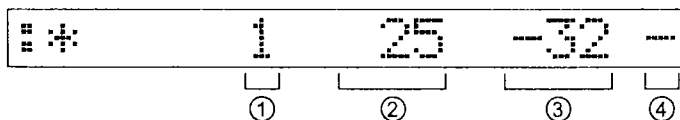

① Stitch data number (the above example is 1st stitch)

② X data

③ Y data

④ Function code (\*2)

\* 2: S: Stop, J: Jump, H: High speed, L: Low speed, A: ATH, P: Sequin, E: End, -: Stitch

#### <Required Setting Items>

Setting Item	Setting Range
Design data number (memory)	1 to 99
Stitch data number	1 to n (the last stitch number of the selected design)
X data	-12.7 to 12.7 mm
Y data	-12.7 to 12.7 mm
Function code	S: Stop, J: Jump, H: High speed, L: Low speed, A: ATH, P: Sequin, E: End, -: Stitch

1. Select the Data Edit (Modify) function.



Press the edit key to display the screen title as shown below.

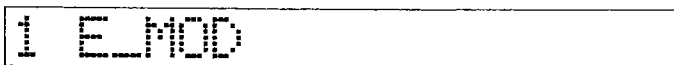

**SET**



Press the [SET] key to decide the selection.



① The screen displays the smallest design data number among the design data numbers registered in memory. If the "data edit (modify)" is selected during embroidery, the screen displays the set design number with its design name.

2. Select the design data number to be edited.



Select design data number by turning the jog dial [Ex.: 5 (SAKURA)].



**SET**



Press the [SET] key to decide the selection.

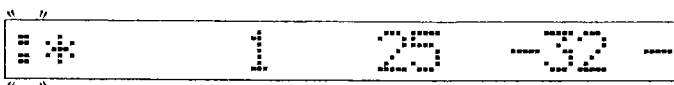

3. Select the target stitch.

<Without using the search function>: Use the jog dial or jog shuttle to select the stitch data.

SET



Press the [SET] key to decide the selection of the stitch data.

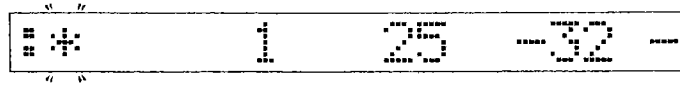

**NOTE:** If selection is performed during embroidery, the current stitch data is displayed. In this case, only the current stitch and after can be selected.

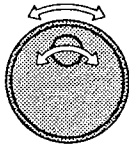

Select the stitch data by turning the jog dial or jog shuttle [Ex.: 348th stitch].



SET



Press the [SET] key to decide the selected stitch data.



This completes the stitch number selection. Proceed to the procedure 4. "Modify the X data" (p.3-15).

<Using the search function>: Specify the function code to select the stitch data.

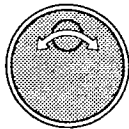

Select the function code to be searched for by turning the jog dial [Ex.: S (Stop)].

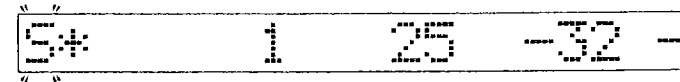

SET



Press the [SET] key to execute searching.

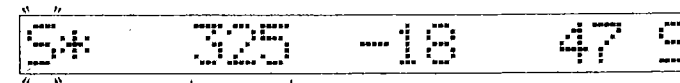

①

① The first stitch that contains the selected function code "S (Stop)" is located.

**NOTE 1:** If searching is performed during embroidery, only the present stitch and the following stitches can be searched.

NOTE 2: Every time the [SET] key is pressed, containing the same function code will be searched one by one.

NOTE 3: If the selected function code is not found, the display remains unchanged.

NOTE 4: It is also possible to select other function codes by turning the jog dial.



SET



Press the [SET] key to continue searching until the target stitch data is displayed [Ex. 348th stitch].

5\* 348 -49 62 5



Select " " by turning the jog dial.

\* 348 -49 62 5



SET



Press the [SET] key to decide the selection.

\* 348 -49 62 5



SET



NOTE: It is also possible to select the stitch data by turning the jog dial. If selecting is performed during embroidery, only the present stitch and the following stitches can be selected.

Press the [SET] key to decide the selected stitch data.

348 X -49 Y 62 5

This completes the stitch number selection. Proceed to the procedure 4. "Modify the X data" (p.3-15).



Select the X data value after modification by turning the jog dial [Ex.: +26 (+2.6mm)].



**SET**



**NOTE:** If it is not necessary to modify the X data, simply press the [SET] key to advance to the next step for modifying the Y data.

Press the [SET] key to decide the selected value.



5. Modify the Y data.



Select the Y data value after modification by turning the jog dial [Ex.: -39 (-3.9mm)].

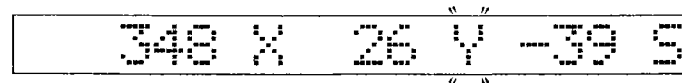

**SET**



Press the [SET] key to decide the selected value.



6. Modify the function code.



Select the function code after modification by turning the jog dial [Ex.: J (Jump)].

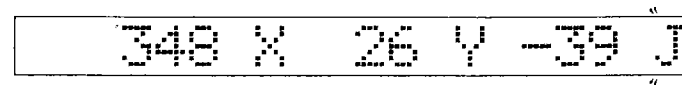

**SET**



Press the [SET] key to decide the selected value.

The screen displays the moved-up by one stitch data.

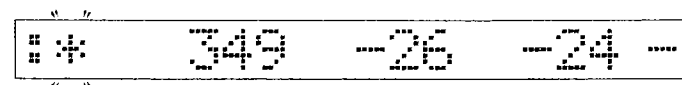

Return to the procedure 3. "Select the target stitch" (p.3-13) to select the stitch to be modified.

### <Ending the Data Edit (Modify) function>

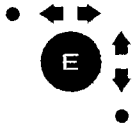

Press the manual frame travel mode key.  
The screen returns to the "normal display" (p.2-9).

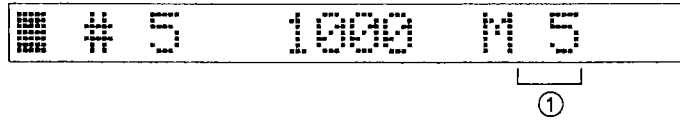

- ① The screen displays the selected design data number (It is possible to continue the embroidery).

**NOTE:** Actual display differs depending on the setting contents.

This operation inserts stitch data to the design data registered in memory.

Insertion of stitch data is possible in one stitch unit and the search function can be used for locating the data insertion position.

Menu Key	Screen Number
	2

**NOTE: The stitch data is inserted just before the target stitch data of which position is selected as the location of data insertion.**

### <Setting and Screen Display>

- When selecting design data number



① Design data number

② Design name (\*1)

\* 1: Design name is displayed only when a design name is assigned to the design data.

Design name of up to 8 characters may be displayed.

- When editing design data



① Stitch data number (the above example is 1st stitch)

② X data

③ Y data

④ Function code (\*2)

\* 2: S: Stop, J: Jump, H: High speed, L: Low speed, A: ATH, P: Sequin, E: End, -: Stitch

### <Required Setting Items>

Setting Item	Setting Range
Design data number (memory)	1 to 99
Stitch data number	1 to n (the last stitch number of the selected design)
X data	-12.7 to 12.7 mm
Y data	-12.7 to 12.7 mm
Function code	S: Stop, J: Jump, H: High speed, L: Low speed, A: ATH, P: Sequin, E: End, -: Stitch

1. Select the Data Edit (Insert) function.



Press the edit key to display the screen title as shown below.



**SET**



Press the [SET] key to decide the selection.



- ① The screen displays the smallest design number among the design numbers registered in memory.  
If "Data Edit (Insert)" is selected during embroidery, the design data number and the design name are displayed.

2. Select the design data number to be edited.



Select design data number by turning the jog dial [Ex.: 5 (SAKURA)].



**SET**



Press the [SET] key to decide the selection.

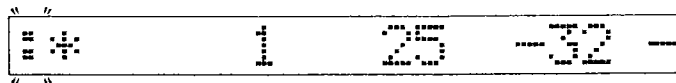

3. Select the target stitch.

<Without using the search function>: Use the jog dial or jog shuttle to select the stitch data.

SET



Press the [SET] key to decide the selection of the stitch.

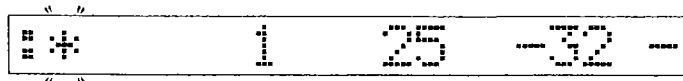

**NOTE:** If selection is performed during embroidery, the current stitch data is displayed. In this case, it is only possible to select the current stitch and after.

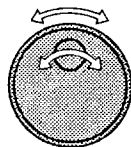

Select the target stitch data by turning the jog dial or jog shuttle [Ex.: 348th stitch].

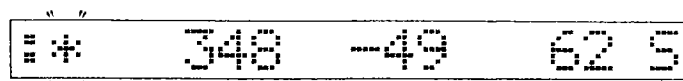

SET



Press the [SET] key to decide the selected stitch data.



This completes the stitch number selection. Proceed to the procedure 4. "Set the X data" (p.3-21).

<Using the search function>: Specify the function code to select the stitch data.



Select the function code to be searched for by turning the jog dial [Ex.: S (Stop)].

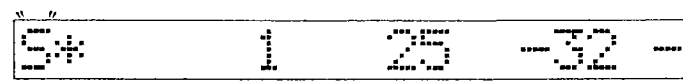

SET

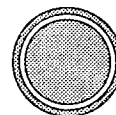

Press the [SET] key to execute search.

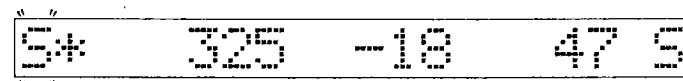

① The first stitch that contains the selected function code "S (Stop)" is located.

**NOTE 1:** If searching is performed during embroidery, only the present stitch and the following stitches can be searched.